

Benefits by design and installation to protect your electrical system by using MCCB / MCB's with back-up protection by HRC fuse links

Rahul Sharma

Abstract— In the modern world it is seen that due to short circuit / overloading our household, industries, transportation systems like trains etc. are facing deleterious effects like fire and explosions, which most of the times creates destructive results for men and materials. Hence it became mandatory to innovate a new and perfect blend technology which the dually reduces the risk of failure but is all time energy efficient too. This technology was rigorously tested on each and every part however to make it insignificant that might to perk up actual functioning of the installation. This paper describes the new approach for installation and protection that ensures security against extreme internal faults. Inrush and over execution condition, that provides benefits by its design and installation, protect your electrical system by using moulded case circuit breaker (MCCB) and miniature circuit breaker (MCB's) with back-up protection of high rupturing capacity (HRC) fuse links.

Index Terms— moulded case circuit breaker, miniature circuit breaker, high rupturing capacity, amperes, volts, root mean square, degree centigrade



1 INTRODUCTION

Let's introduce to you a perfect blend technology the HRC fuse link as well as MCCB's / MCB's. Both are generally used in industries, household, some of transportation systems like trains etc. to protect from overloading and short circuits and for other protections. Both these electrical equipments are used on different places on basis of their own importance, limitations and features.

2 SHORT CIRCUIT SYMMETRICAL

If the fault level of short circuit is greater than 50 kilo amperes (kA) with power factor 0.25 and cut-off current 30 kA, 25 kA and 10 kA and with recovery voltage. Phase values of root mean square (V_{rms}) 25 kilo Volt (kV) per phase and voltage between phase values V_{rms} 440 V the MCCB / MCB's will burn,

but HRC fuse link (the breaking capacity of greater than 80 kA) can protect whole installation (with back-up protection) and also protect MCCB / MCB's.

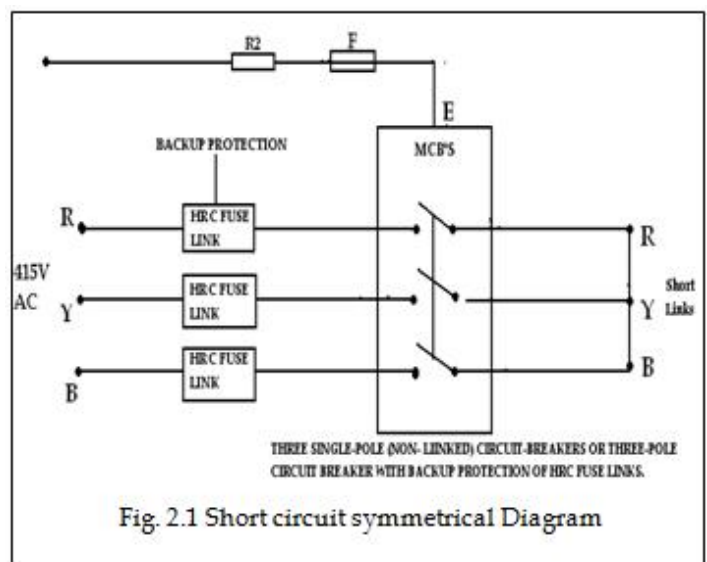

Fig. 2.1 Short circuit symmetrical Diagram

• ¹ DAV Institute of Engineering and Technology, Punjab Technical University, Kapurthala-144601, Punjab, India, PH- +919780086665. E-mail: rahulruddra@gmail.com

Mostly we can use MCCB / MCB's for protection purpose in electrical system. But we can't test the MCCB / MCB's before short circuit / over-loading it will work or not (Electro-mechanical devices)

So, first of all we install all MCCB / MCB's according to our need and then do mock drill exercise by short circuit / over-loading and then we can know that all MCCB / MCB's are working or not. Because sometimes they do not work when needed then HRC fuse link protect whole circuit.

To avoid failure of MCCB / MCB's we can provide HRC fuse links for back-up protection. Always adopt the blend technology.

Table 2.1 Phase voltages and current values

Phase:	:-	R	Y	B
Prospective breaking current:				
Phase values (kA _{rms})	:-	50 kA		
Power factor:				
Phase values (average)	:-	0.25		
Cut-off current (kA)	:-	30kA	25kA	10kA
Recovery voltage:				
Phase values (V _{rms})	:-	254V	254V	254V
Voltage between phase values	:-	440V		

3 HRC FUSE LINKS

The rupturing capacity is less than 80 kA with power factor 0.35. Its design preferred the breaking capacity less than 50 kA. Their body structure is light and court right with the thermal shock of 800 degree centigrade (°C).

These are easily replaceable after short circuit and in blow condition the ambient / climates not affect its body due to silica sand filling because silica sand has highest suffering capacity to absorb the fault level and ruptures the heavy flash or jerk. No other device having such capacity during short circuit.

The fusing factor of HRC fuse links is 1.6 times and non-fusing is 1.2 times. It helps in controlling the vibration, low temperature and power loss. It does not affected by the weather also due to body enclosure fuse.

All the HRC fuse links provide their uninterrupted duty for long time due to presence of silica sand, it always set it cool and due to this coolant factor the chances of caught fire are almost zero percent.

These are very low in weight and also unbreakable. The detective and mechanical strength is too high and insulation resistance is more after overloading and short circuits.



Fig. 3.1 HRC Fuse Links

4 MCCB AND MCB'S

The breaking capacity of MCCB/MCB is not over than 25 kA and it is also expensive and non-repairable. After short circuit these may not workable due to affected by overloading.

All MCCB/MCB's are fully depends on Ambient/Weather and tripping time is not controlled on overload/inrush and totally damaged in short circuit.

Due to electromechanical design it is more affected by vibration and high temperature and interrupted duty. The Dielectric strength is low after short circuit and insulation resistance is less after overloading/short circuit.

5 RESULTS FEATURED OF HRC OVER MCCB

Table 5.1 Comparison of HRC and MCCB

S.No.	Disconnecter with HRC Fuse	MCCB
1.	The breaking capacity is >80kA	Not more than 20kA
2.	Cost of HRC Fuse less	More expensive
3.	It must be repairable	Not repairable
4.	Not affected by ambient	Fully depend on ambient
5.	Fusing - 1.6 time Non Fusing - 1.2 time	Tripping time not controlled on overload
6.	After heavy short circuit only HRC Fuse to be replaced	After heavy short circuit MCCB is totally damaged
7.	The incoming, outgoing terminals are suitable as per cable size	Fixed terminals
8.	Not defected by vibrations	Due to electromechanical design, more affected by vibrations
9.	Less temperature rise	High temperature rise
10.	Not affected by weather	Affected by weather
11.	Un-interrupted duty	Interrupted duty
12.	Less weight	Heavy weight
13.	Unbreakable	Breakable
14.	Dielectric strength is more after short circuit/overloading	Dielectric strength is less after short circuit/over loading
15.	Insulation resistance is more after overload/short circuit	Insulation resistance is less after overload/short circuit

6 CONCLUSION

In power system the safety factor and then dependability is very important. As per electrical engineering HRC fuse links provides us more safety, dependability and durability.

We cannot rely only through MCCB and MCB's for protection unless we do not provided back up protection of HRC fuse links. Then the circuit with backup protection cover ensures the safety, dependability and durability and we can also rely on electrical system. Switchgear up to 80A to be mechanically fastened and electrically contacted safely and easily to the bus bar system. The chances of accident are low due to this design based on full proof blend technology.